

MEN Mikro Elektronik GmbH

Rugged Computer Boards and Systems for Harsh, Mobile and Mission-Critical Environments.



Safe Communication for Inflight Systems



“Moore’s Law” for Aviation Systems

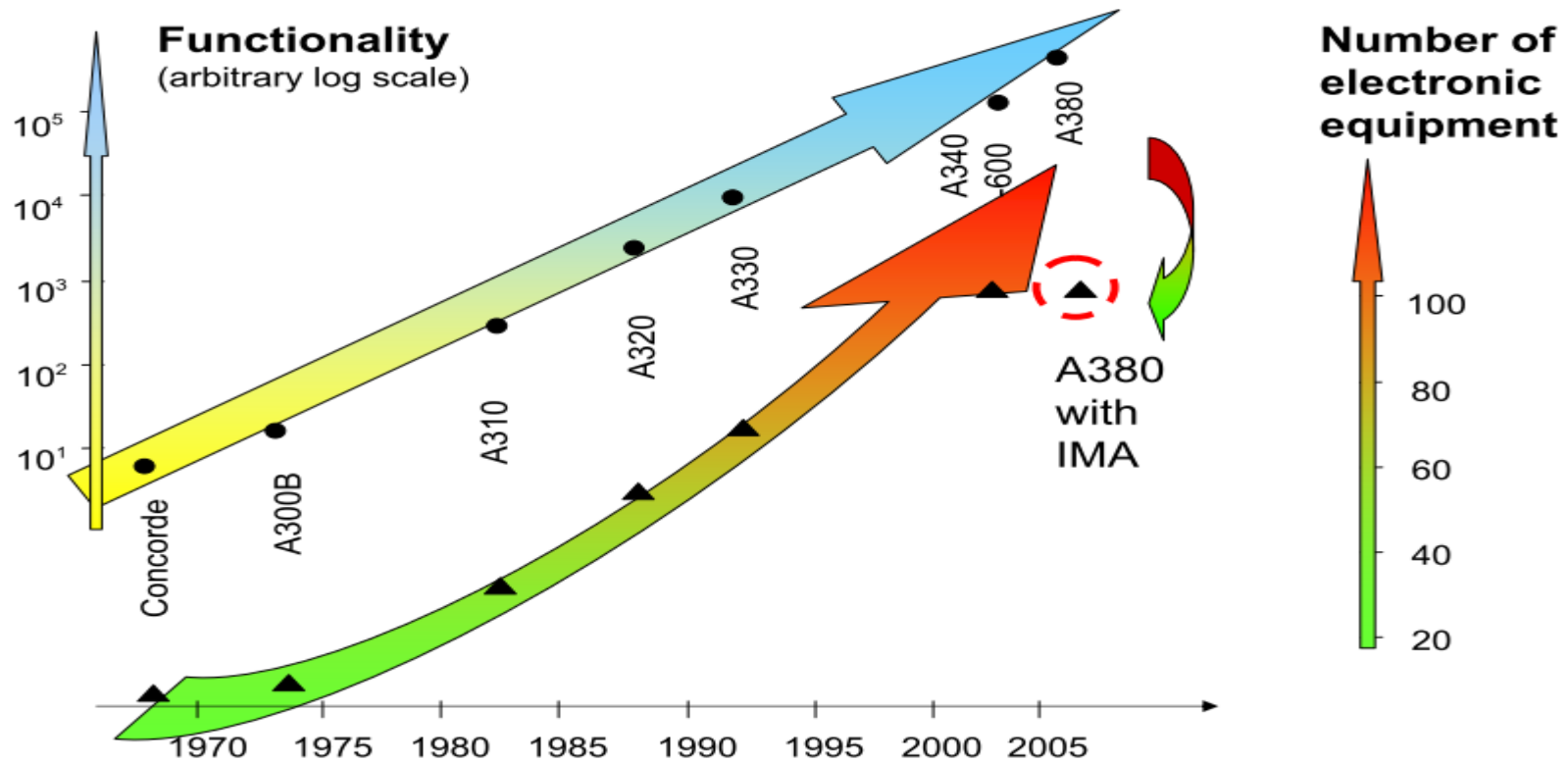

Legacy Architecture is at it's Limit

Where We Come From: ARINC-429 (Aircrafts of the 80s)

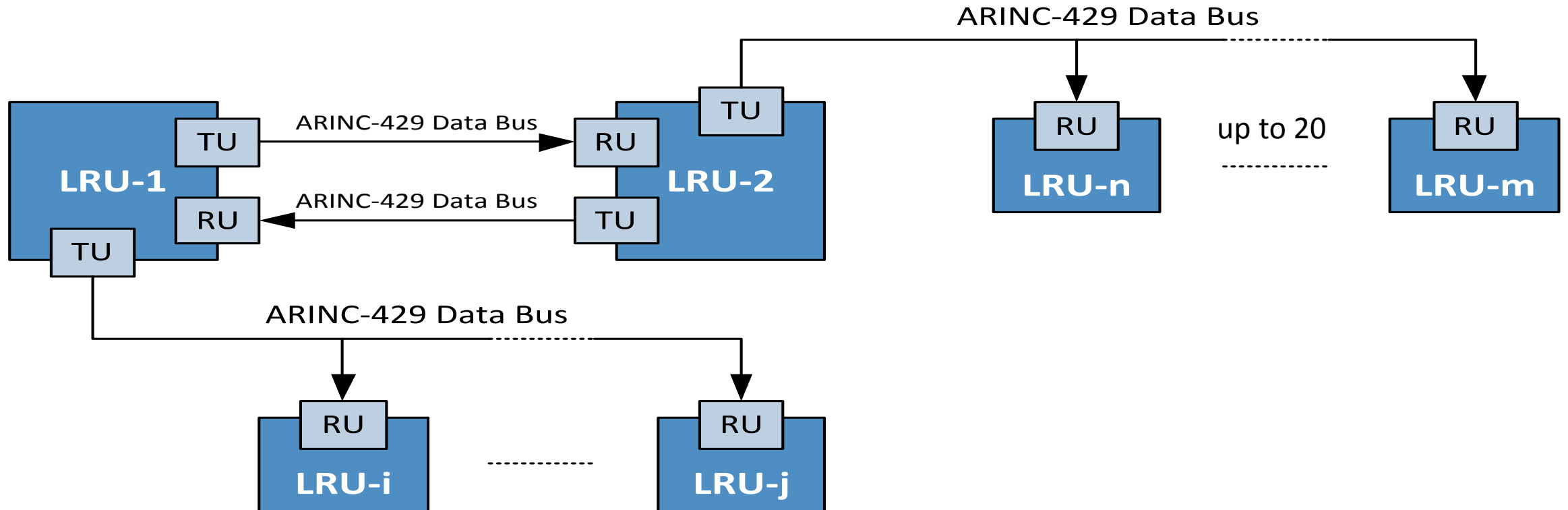

MIL-STD-1553

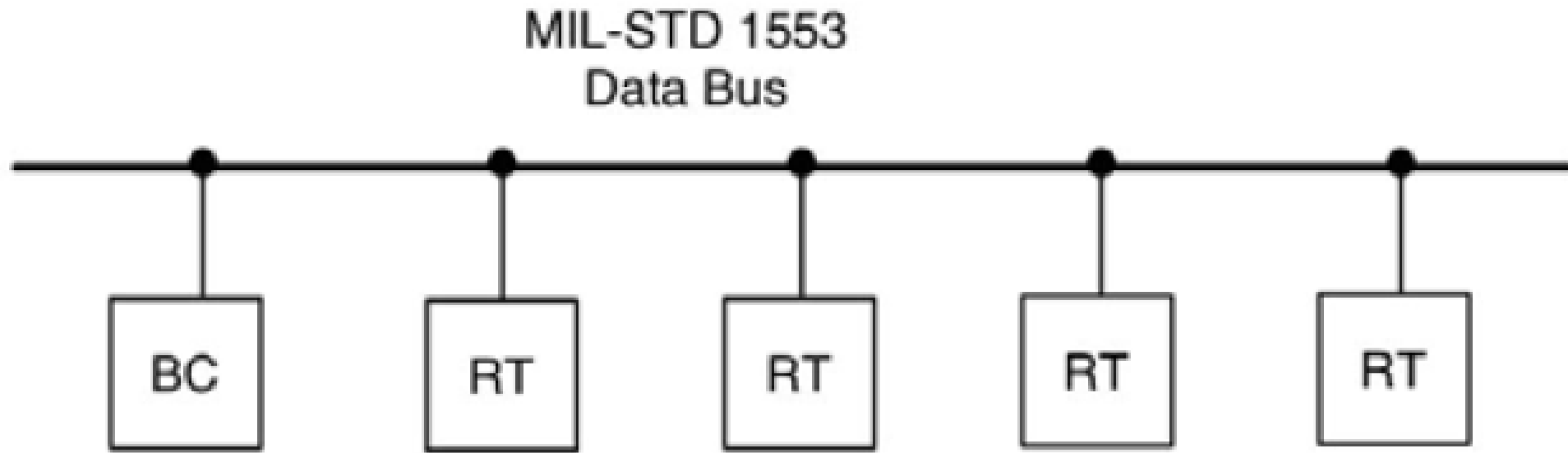

Performance

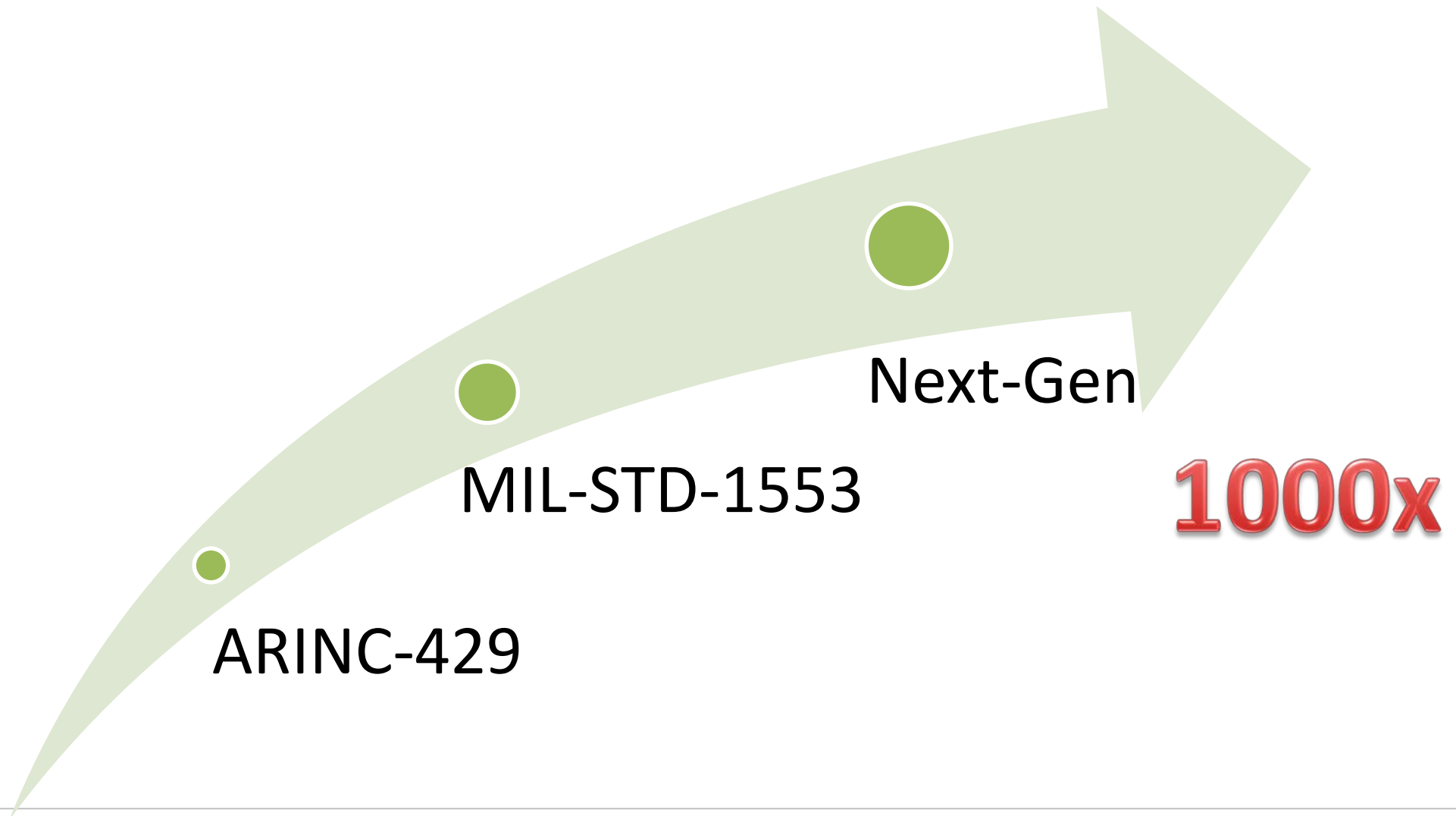

What do You Expect from a Next-Gen Interface



Next-Gen

IEEE 802.3 standard Ethernet Technology

*Deterministic
Timing*

**Guaranteed
Bandwidth**

**Physical
Redundancy**

Safety

**Virtual Link
Communication**

Avionic Full Duplex Switched Ethernet (AFDX)

AFDX Topology Overview

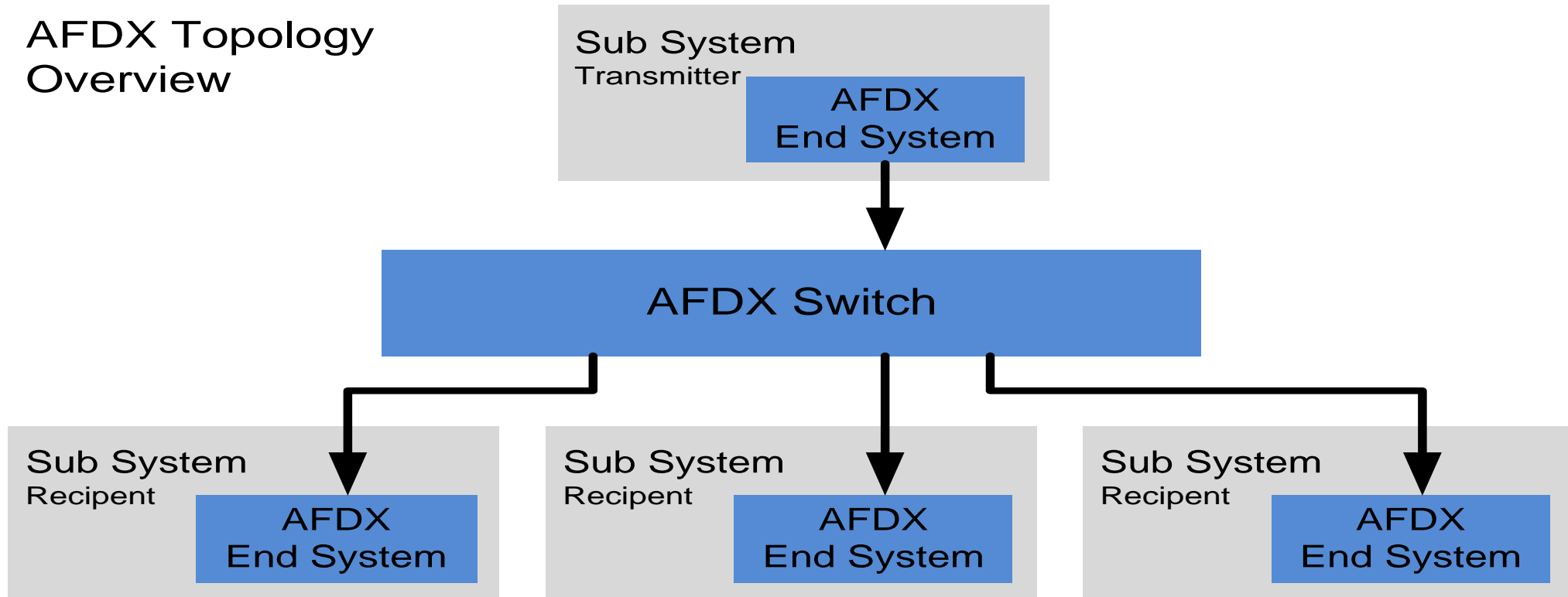

Standardized as ARINC664 Part7

AFDX Redundancy

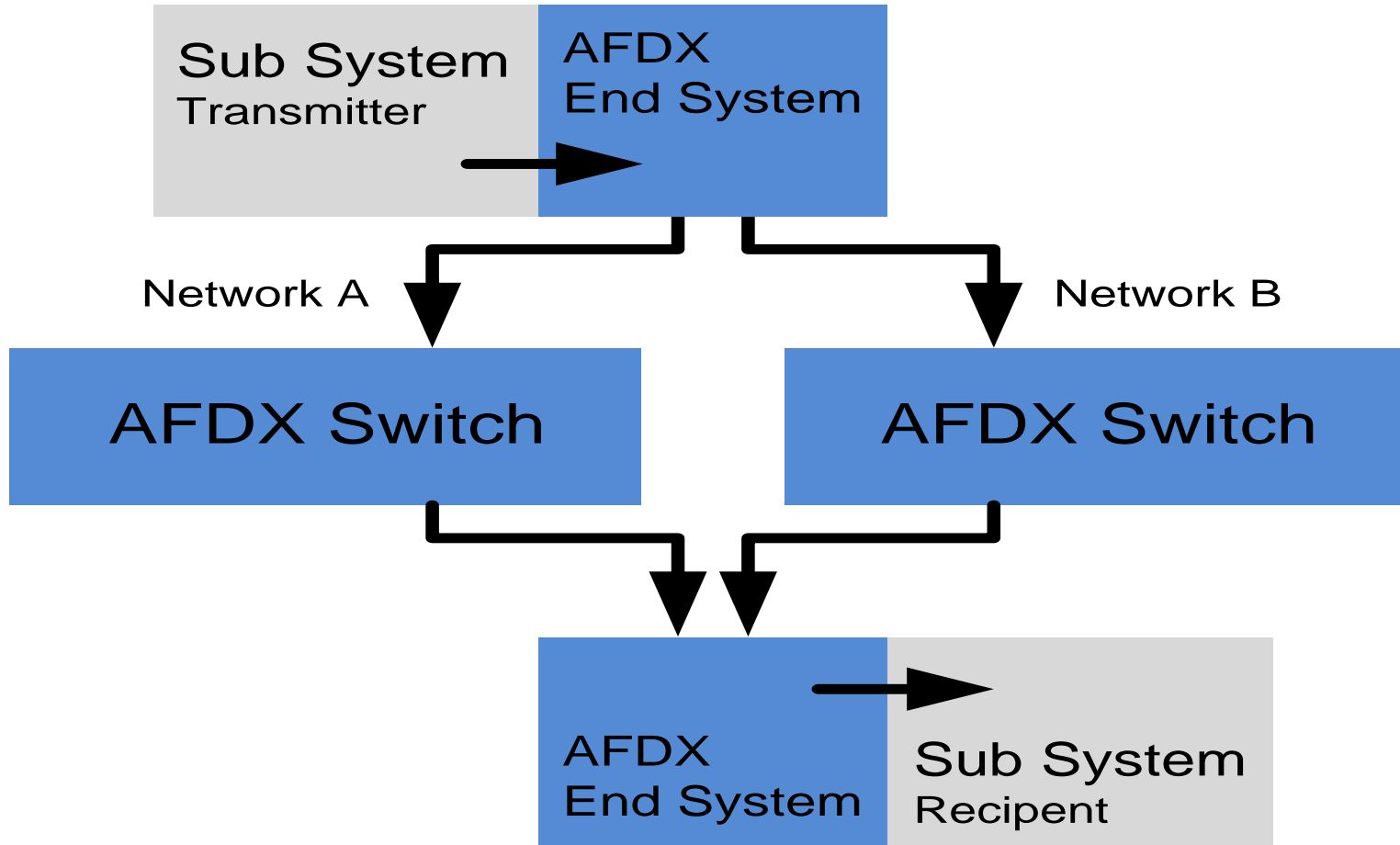

Virtual Links replace ARINC-429

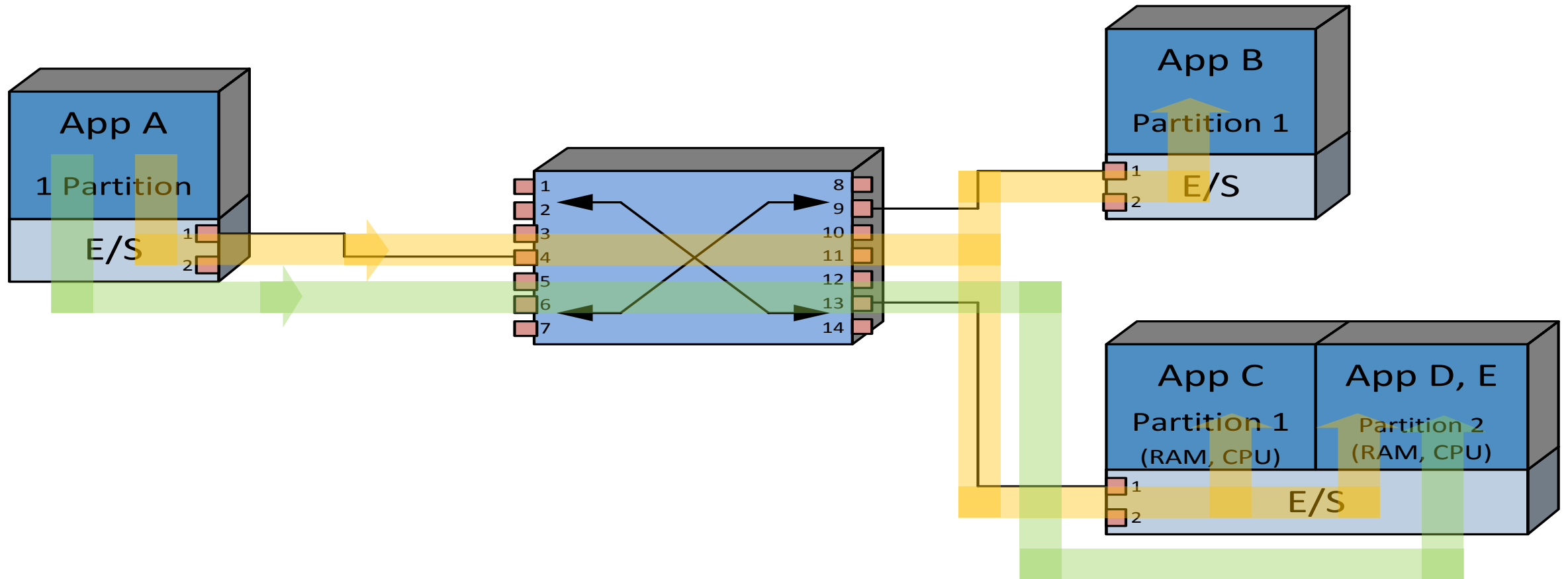

A380 AFDX Concept

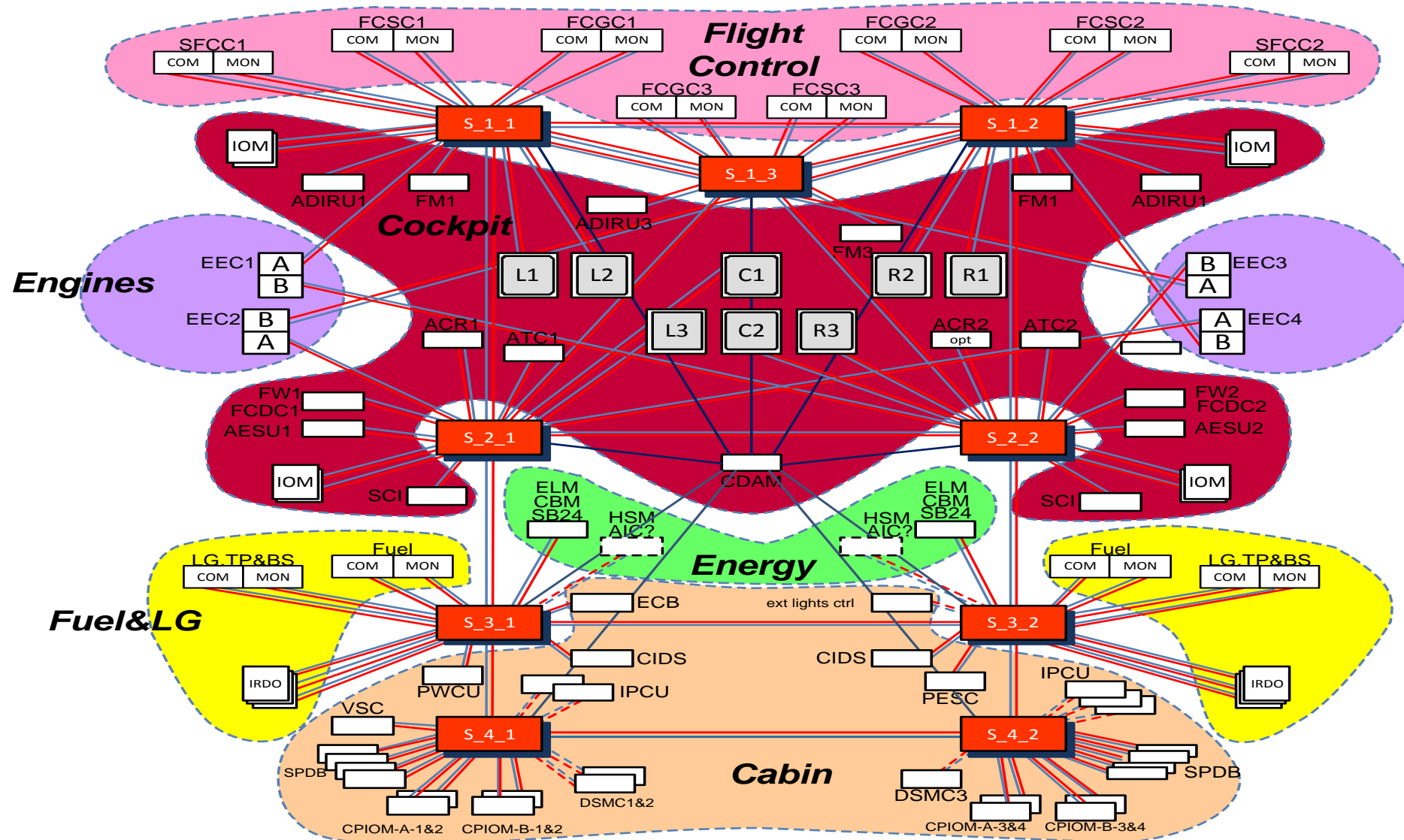

Current Usage



Midterm Solution



**Single Chip
AFDX
Solution**

Longterm Solution – IoT in an Airplane



Why we Need All of That?

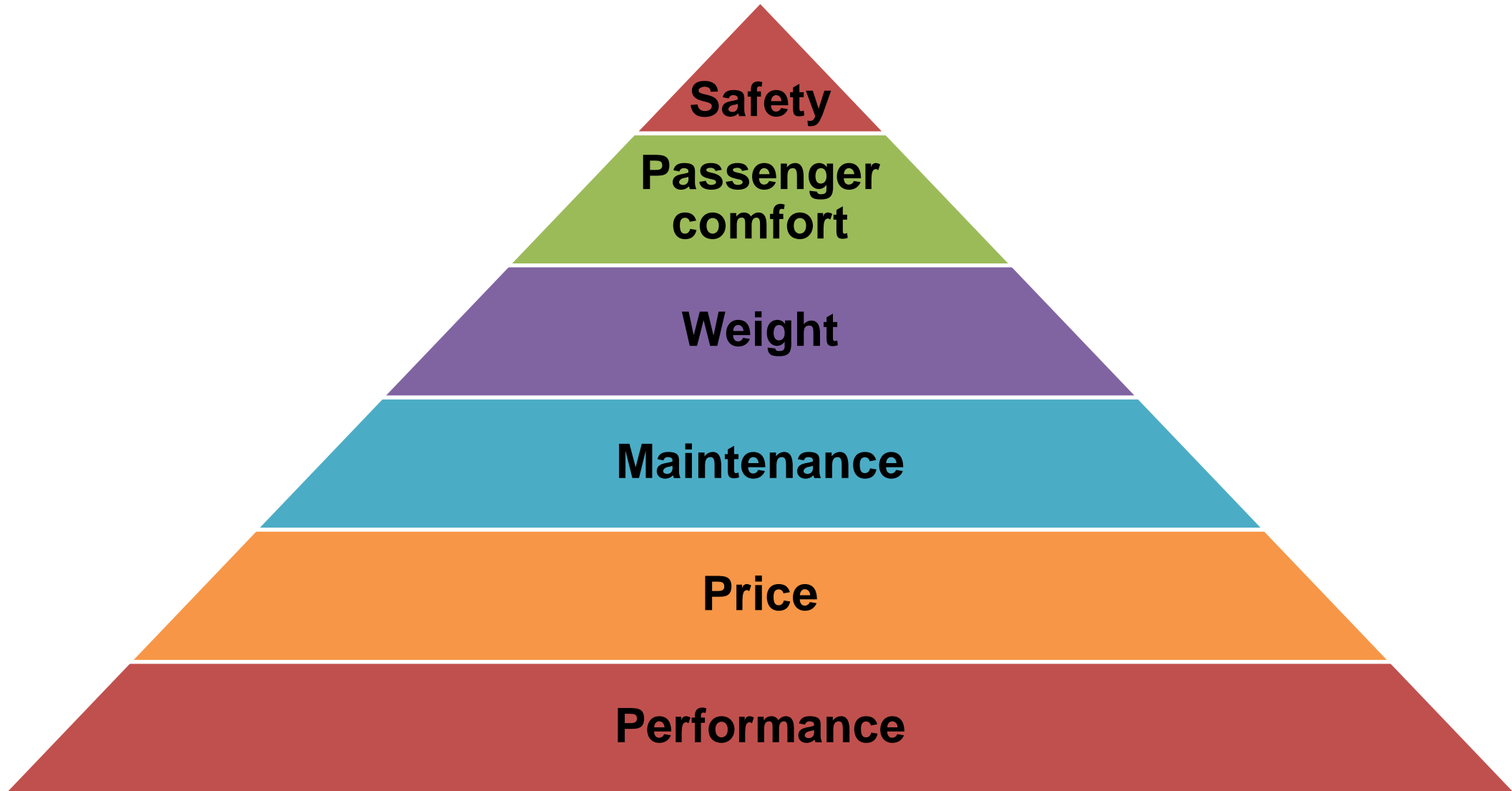



*mca*micro.com

mca.de

mca-france.fr